

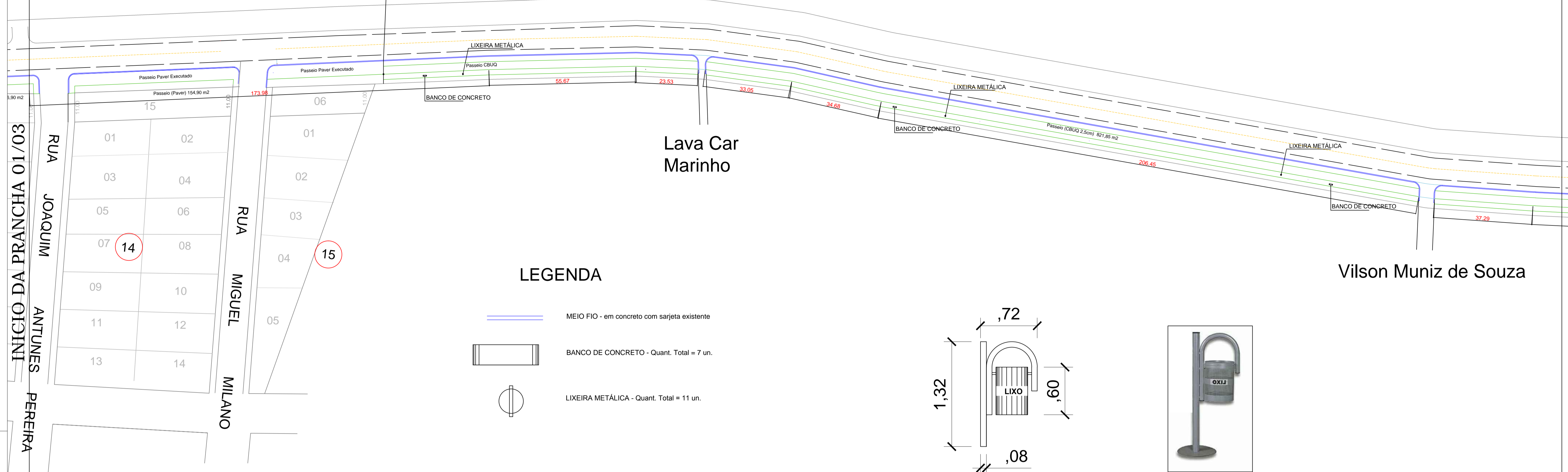



INICIO DA 1ª ETAPA

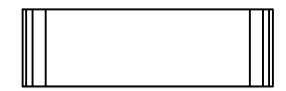

LEGENDA

-  MEIO FIO - em concreto com sarjeta existente
-  BANCO DE CONCRETO - Quant. Total = 7 un.
-  LIXEIRA METÁLICA - Quant. Total = 11 un.

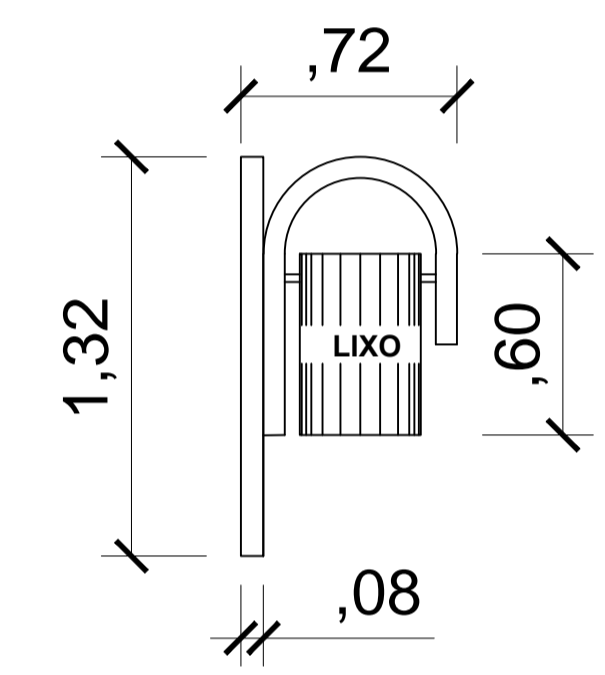

Detalhe Lixeira
Escala 1:25



Imagem de Referência

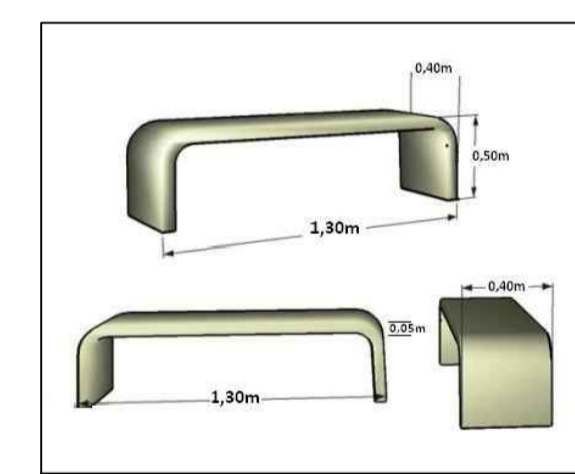

Detalhe Banco
Escala Sem



Imagem de Referência

PLANTA DE URBANIZAÇÃO - LOCAÇÃO DE CALÇADAS
Escala:.....1/750

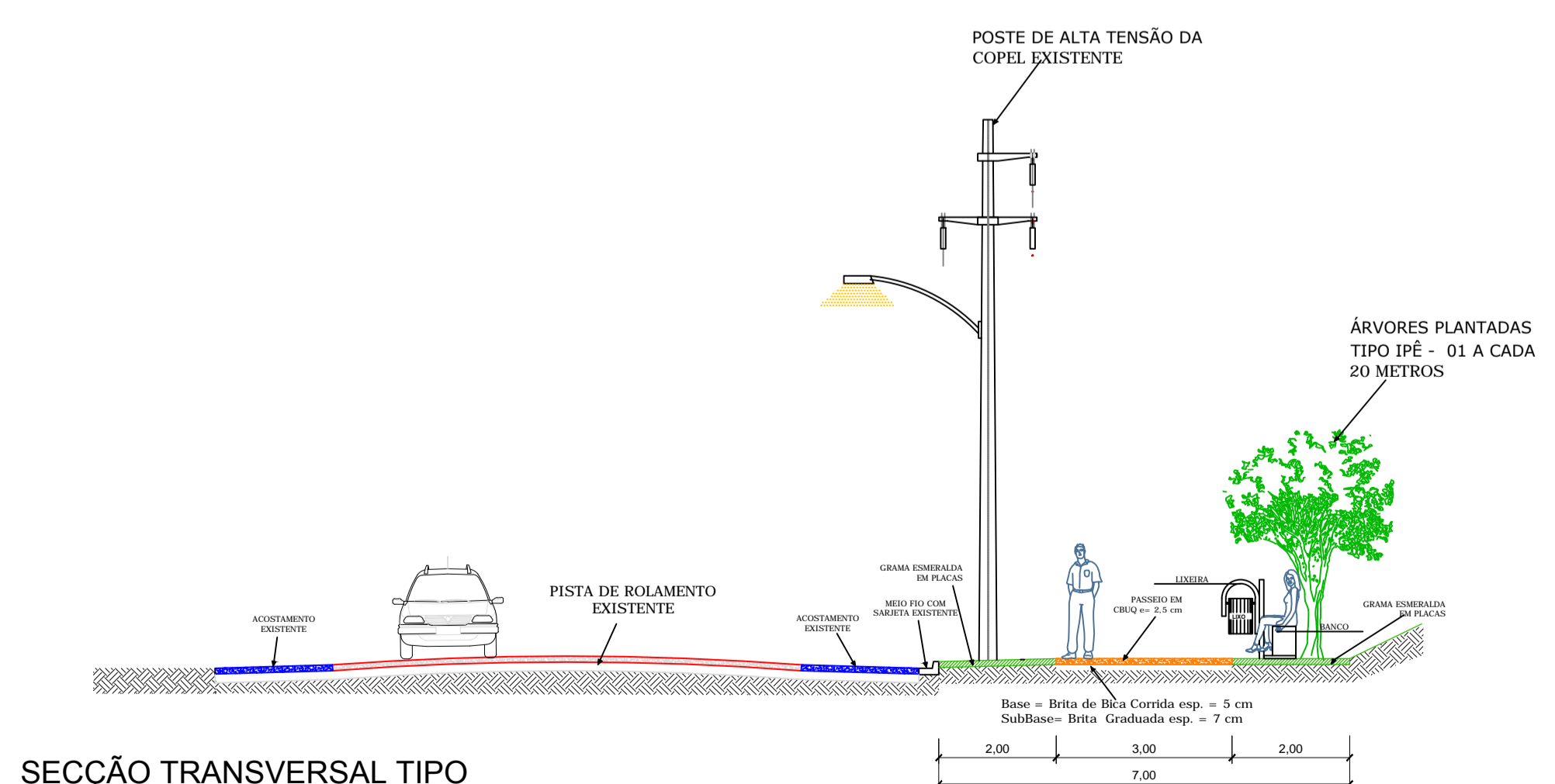

SECÇÃO TRANSVERSAL TIPO

Escala:.....1/100

ARTICULAÇÃO DE PRANCHAS

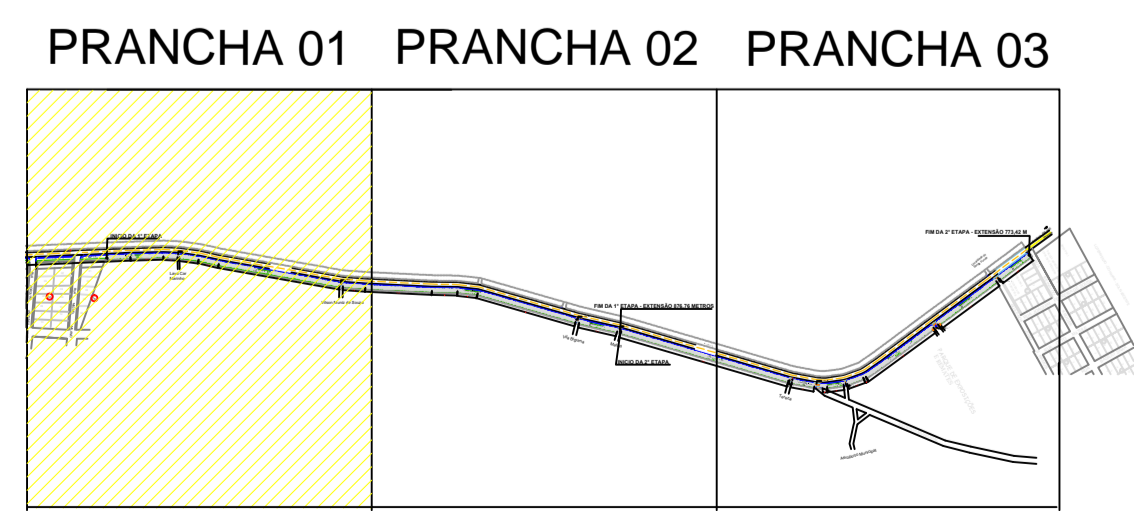

CONTINUA NA PRANCHA 02/03

PREFEITURA MUNICIPAL DE PALMITAL

DEPARTAMENTO DE ENGENHARIA **01/03**

OBRA: **- PROJETO DE URBANIZAÇÃO - INFRA-ESTRUTURA URBANA**

ENDEREÇO DA OBRA: **AVENIDA DAS PALMEIRAS**

CONTEÚDO: **PROJETO DE URBANIZAÇÃO (Equipamentos Urbanos)**

PROPRIETÁRIO: **Prefeito Valdenei de Souza**
Prefeitura Municipal de Palmital
CNPJ: 75.680.025/0001-82

RESPONSÁVEL TÉCNICO PELO PROJETO: **Eduardo Orestes Tomen**
Engenheiro Civil - CREA-PR - 80402/D

LOCALIZAÇÃO DO TERRENO: 

AUTENTICAÇÕES: 

DESENHO: **Darian** ESCALA: **Indicada** **Palmital, 09 de Outubro de 2017.**